

PROFILE CUTTER

Individual profiles on four-sided planers and other machines

Design

- CAT profile cutter in Z=2
- Single cutter or fully mounted on HSK Powerlock clamping shaft
- For mechanical feed (MEC)
- Tool body made of aluminium or steel
- Max. tool diameter (D-Max) = 240 mm
- Tool bore (d) = 25/30/35/40/50 mm (double keyway optional)
- Min. base diameter (D-base) = tool bore +75 mm
- Blade width (B) = 25, 35, 45, 55, 65, 80 mm
- Axial angle max. +/- 10° for all widths
- Profile depth (T) max. 20-25 mm depending on blade width and axial angle
- Prices according to separate price list or on request

Benefits

- Faster blade changes with precise, supported blade positioning
- Screws easily accessible – regardless of axial angle
- Convenient fixing with minimal effort of just 6 Nm
- Secure and comfortable interlocking positioning
- Fast and professional blade changes with no loose parts

Range

Designation	B	T	d	DKN	D
CAT Profile cutter 25	25	Max. 20–25	25–50	optional	Max. 240
CAT Profile cutter 35	35	Max. 20–25	25–50	optional	Max. 240
CAT Profile cutter 45	45	Max. 20–25	25–50	optional	Max. 240
CAT Profile cutter 55	55	Max. 20–25	25–50	optional	Max. 240
CAT Profile cutter 65	65	Max. 20–25	25–50	-	Max. 240
CAT Profile cutter 80	80	Max. 20–25	25–50	-	Max. 240

Mounting on HSK Powerlock clamping shaft

- Hardened and machined design
- Independent of direction of rotation
- Tension via 3 bolts at shaft end
- Clamping cover in catch ring design
- Fine balanced for speeds up to 12,000 rpm
- High true-running accuracy

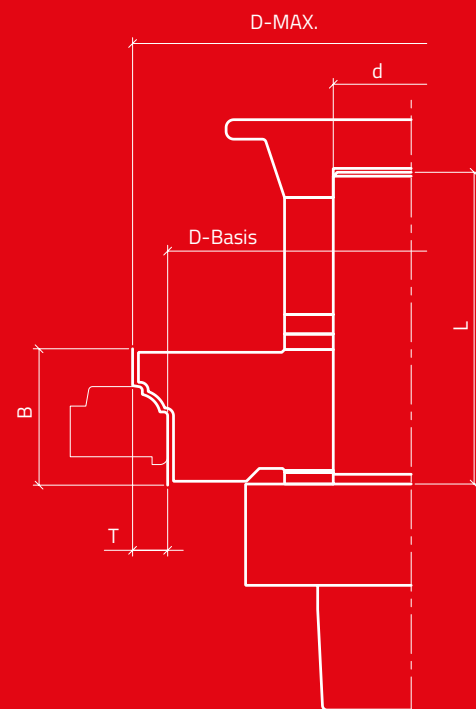

 CAT Flyer



 CAT Video

CAT Details
see QR Code

For further information,
please contact:

+41 44 863 75 11
vertrieb@oertli.com

CASTOR Sprint

Planing on four-sided planers and other machines

Design

- Reversible blades with 4 cutting edges
- The spiral angle pulls from the outside inwards / pull-through cut
- Tool body in aluminium
- Optimal cut division
- Customised special dimensions possible

Benefits

- **Savings in working time** due to less reworking
- **Reduced investment costs** thanks to reversible blade design
- **Competitive advantage** through lower production costs
- Consistent or **higher quality**

Range

Art. No.	D mm	D mm	Z	n-max	width mm	spindle	application
TB860204	125	40	Z=4 (2+2)	12000	130	Right/left	planing
TB860205	125	40	Z=4 (2+2)	12000	180	Top/bottom	planing
TB860206	125	40	Z=4 (2+2)	12000	210	Top/bottom	planing
TB860207	125	40	Z=4 (2+2)	12000	230	Top/bottom	planing
TB860209	125	40	Z=4 (2+2)	12000	240	Top/bottom	planing
TB860403	140	40	Z=4 (2+2)	12000	130	Right/left	planing
TB860404	140	40	Z=4 (2+2)	12000	180	Top/bottom	planing
TB860405	140	40	Z=4 (2+2)	12000	210	Top/bottom	planing
TB860406	140	40	Z=4 (2+2)	12000	230	Top/bottom	planing
TB860407	140	40	Z=4 (2+2)	12000	240	Top/bottom	planing



Castor details
see QR Code

**For further information,
please contact:**

+41 44 863 75 11
vertrieb@oertli.com

SINUS planer head

Fine planing on four-sided planers and other machines

Design

- Hardened and machined precision blade-holder
- Available in Z=2 and Z=4
- Tool body made of high-strength aluminium
- Accurate and sustainable self-adjustment by centrifugal force
- No clamping screws required

Benefits

- Precise, sustainable positioning
- Easy, fast and safe blade replacement
- Optimal true-running accuracy
- Precision blade-holder with chipbreaker function
- Optimal chip ejection

Range

Tool body in aluminium, version with polished cabride HW blades

Art. No.	D	B	d	Z	n max.
TA569228	125	100	40	2	8'500
TA569223	125	130	40	2	8'500
TA569218	125	180	40	2	8'500
TA569226	125	230	40	2	8'500
TA569232	140	100	40	2	8'500
TA569233	140	130	40	2	8'500
TA569234	140	180	40	2	8'500
TA569235	140	230	40	2	8'500

Tool body in aluminium, version with HS-TRI blades

Art. No.	D	B	d	Z	n max.
TA469228	125	100	40	2	8'500
TA469223	125	130	40	2	8'500
TA469218	125	180	40	2	8'500
TA469226	125	230	40	2	8'500
TA469232	140	100	40	2	8'500
TA469233	140	130	40	2	8'500
TA469234	140	180	40	2	8'500
TA469235	140	230	40	2	8'500

SINUS planing blades

- 2 cutting edges per planing blade
- HS-TRI version: Double-sided, one-time regrindable: Particularly suitable for softwood without glued joint
- Polished HW version: Can be reground three times due to larger blade protrusion: Particularly suitable for hardwoods
- Both versions can be used in the same tool body

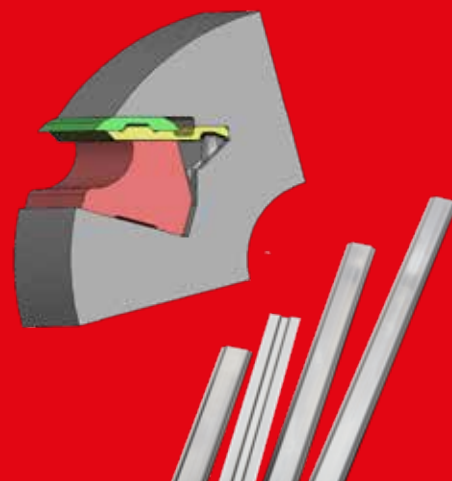

SINUS details
see QR Code

**For further information,
please contact:**

+41 44 863 75 11
vertrieb@oertli.com

CLAMPING SHAFT HSK-P

- E.g. for WEINIG Powermat machines
- Clamping shaft for holding tools with borehole

Design

- Hardened and machined design
- Independent of direction of rotation
- Tension via 3 bolts at shaft end
- Clamping cover in catch ring version
- Fine balanced for speeds up to 12,000 rpm
- High true-running accuracy

Range

HSK clamping shaft			
HSK-P			
Art. No.	d	L1	n max.
TB200040	40	73,5	12'000
TB200041	40	103,5	12'000
TB200042	40	133,5	12'000
TB200043	40	137,5	12'000
TB200044	40	243,5	12'000
TB200045	40	308,5	8'000

Catch ring – cover	
TB200047	D=95 d=40 B=20

Screw for catch ring (3 pieces)	
TB851005	pan head screw, M8 x 50 mm Torx T45



For further information,
please contact:

+41 44 863 75 11
vertrieb@oertli.com

SPACERS HSK-P

Range

Spacers					
Art. No.	d	B	D2	NL	Fig.
TA629814	40	0,05	65,00	2/7.0/55	1
TA629816	40	0,10	65,00	2/7.0/55	1
TA629818	40	0,20	65,00	2/7.0/55	1
TA629820	40	0,50	65,00	2/7.0/55	1
TA629822	40	1,00	65,00	2/7.0/55	1
TA629824	40	2,00	65,00	2/7.0/55	1
TA629832	40	5,00	65,00	2/6.5/55	1
TA629831	40	10,00	65,00	2/6.5/55	1
TA629833	40	20,00	65,00	2/6.5/55	1
TA629863	40	30,00	65,00		1
TA629867	40	40,00	65,00		1
TA629869	40	50,00	65,00		1

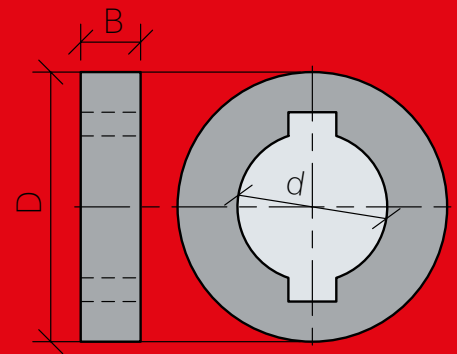

For further information,
please contact:

+41 44 863 75 11
vertrieb@oertli.com

TOOL ASSEMBLY

Range

SINUS blade changer

TA469100	SINUS blade changer
----------	---------------------

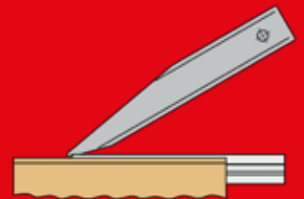

TOOL ASSEMBLY DEVICE

Range

Art. No.

Type

TA676997	HSK-P
----------	-------



For further information,
please contact:

+41 44 863 75 11

vertrieb@oertli.com

MICRONEX planer head

Pre-milling on four-sided planer

Execution

- Combination of reversible knives and CAT profile knives
- Reversible knives Z=2 / CAT profile knives Z=1+1
- Body in Aluminium
- Profile knives can be resharpened
- Only for use in combination with finishing tool on the next spindle
- Version with profile depth 0.45mm when next spindle is set to 0.5-0.7mm
- Version with profile depth 0.7 mm when next spindle is set to 1.0 mm
- Combination of several tools (80 or 100mm) to achieve the spindle width
- Can be combined with rebate cutter TB8604 14 (D=160) and TB8604 15 (D=150)
- Only available in standard dimensions
- A hardened table is strongly recommended if used on the bottom spindle

Your benefit

- Perfect planing surface thanks to OERTLI MICRONEX
- Savings in working time due to less reworking
- Low replacement blade costs thanks to resharpenable CAT knives
- Constant diameter even after resharpening thanks to combination with reversible cutting knives

Assortment

Item no.	D mm	d mm	Z	n-max	Width mm	Profile depth T	Application
TB860410	125	40	2+2	12000	100	0.70	Pre-milling
TB860411	125	40	2+2	12000	100	0.45	Pre-milling
TB860412	125	40	2+2	12000	80	0.70	Pre-milling
TB860413	125	40	2+2	12000	80	0.45	Pre-milling

Replacement blades

Item no.	Description of the	Width mm	Profile depth T	Application
KC11270558	CAT profile knives	100	0.45 & 0.70	Pre-milling
KC12270458	CAT profile knives	80	0.45 & 0.70	Pre-milling
KG217099	WS reversible knives	100		Straight cut
KG217080	WS reversible knives	80		Straight cut

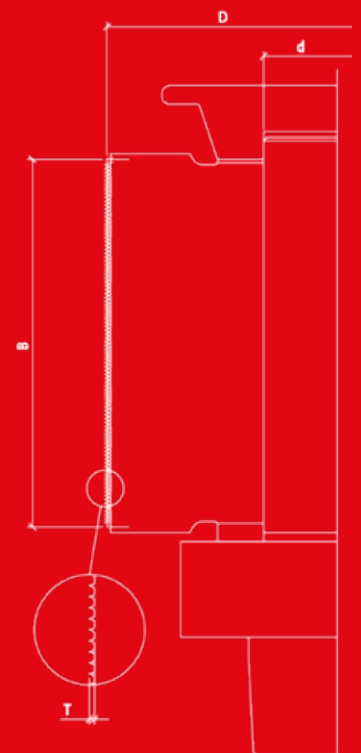

For further information,
please contact:
+41 44 863 75 11
vertrieb@oertli.com

TOOL CASE WITH TORQUE WRENCH

Torque wrench set

Range

Art. No.	Type
TB 100050	17-piece set

Ersatzteile

Art. No.	Designation	Fig.
TA0002990400	Case for torque wrench set	
TA851290	Setting jig W1/W11/W7	
TB100030	Torque wrench straight handle, type=1.0-5.0 Nm	1
TB100031	Interchangeable blade for straight handle, type=ISK 5	2
TB100032	Interchangeable blade for straight handle, type=Torx 15	2
TB100033	Interchangeable blade for straight handle, type=Torx 20	2
TB100034	Interchangeable blade for straight handle, type=Torx 25	2
TB100035	Interchangeable blade for straight handle, type=ISK 2.5	2
TB100036	Interchangeable blade for straight handle, type=ISK 3	2
TB100037	Interchangeable blade for straight handle, type=ISK 4	2
TB100038	Interchangeable blade with magnet, bit holder for straight handle,	3
TB100039	Bit for bit holder, type= Torx 10	4
TB100040	Torque wrench, cross handle, type=3.2-16 Nm	5
TB100041	Interchangeable blade for cross handle, type=Torx 15	6
TB100042	Interchangeable blade for cross handle, type=Torx 20	6
TB100043	Interchangeable blade for cross handle, type=Torx 25	6
TB100044	Interchangeable blade for cross handle, type=Torx 30	6
TB100046	Interchangeable blade for cross handle, Type=ISK 5	6



For further information,
please contact:

+41 44 863 75 11
vertrieb@oertli.com

TOOL CLEANING

Cone cleaner

Range

Art. No.	Designation	Type	Image
TB630001	Cone cleaner for machine spindle	HSK 63E / HSK 85P	1
TB630004	Cone cleaner for tool	HSK 63E / HSK 85P	2



Washing machine

Range

Art. No.	Type	Index
TA635120	Mini, diameter 410 mm, height 180 mm	1
TA635128	Mini with lid extension, diameter 410 mm, height 310 mm	2
TA635121	Standard, diameter 610 mm, height 400 mm	3

Spare parts

Art. No.	Designation	Index
TA635080	Saxin aluminium/steel cleaning agent, type=5 litre	1-3
TA635122	Detergent EM74, type=10kg	1-3
TA635124	EM 200 preservative, type=10kg	1-3
TA635126	Anti-foaming agent EM902, type= 1 litre	1-3
TA635130	Tool holder for HSK 63F	1-3
TA635131	Tool holder for Powerlock	1-3
TB630005	Tool holder for HSK 63E	1-3
TB630012	Small parts basket, 350 x 200 x 175	1-3
TB630013	Trolley for washing machine, type Mini	1,2



For further information,
please contact:

+41 44 863 75 11
vertrieb@oertli.com